

(300)

(80)

Daily greasing  
Detail Joint  
(scale 1:2)

Detail Guide box

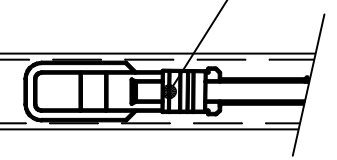
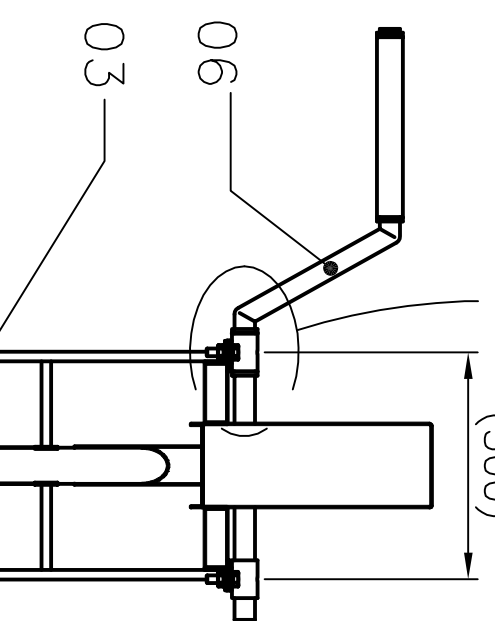

16	8	Washer	Ø 10
15	4	Nut	M10 [Nut 17]
14	4	Bolt	M10 x 35 [Bolt 17]
13	1	Rope inlet	PVC Pipe 1 1/4" - 500mm
12	1	Guide box	Pump Parts - Guide box
11	m	Rope with washers	Pump parts - Rising main
10	m.	Rising main	Pump parts - Rising main
09	1	Outlet	Pump parts - Rising main
08	1	Locker	Handle
07	2	Bushing	Bushing
06	1	Handle	Handle
05	1	Cap	Cap
04	1	Wheel 14"	Wheel 14"
03	1	Frame AB	Frame AB
02	1	Apron	Diameter 3m with soakpit
01	1	Bore hole	Minimum diameter 4"
No	Count	Name	Dimensions

Depth Well	D (rising main)		Reducer		Tee		Outlet	
	m.	feet	mm.	inch.	inch.	inch.	inch.	inch.
0-10	0-33	23	1	3/4	1	1 1/2	1 1/2	1 1/2
10-35	65-115	18	3/4	1 1/2	1 1/2	1 1/2	1 1/2	1 1/2

 	Date:	10-2007	Company:	Pumping = Life	Remarks:
	Dimension:	mm [inch]		Engineer:	
Main scale:	1:10	Layout:	assembly	No of Layouts:	1
Project:		Sumsung Veela (Walewale, Ghana)			
Name:		Rope Pump AB			
Revision:		A			
Revision:		A3			