

Detail frame (03)

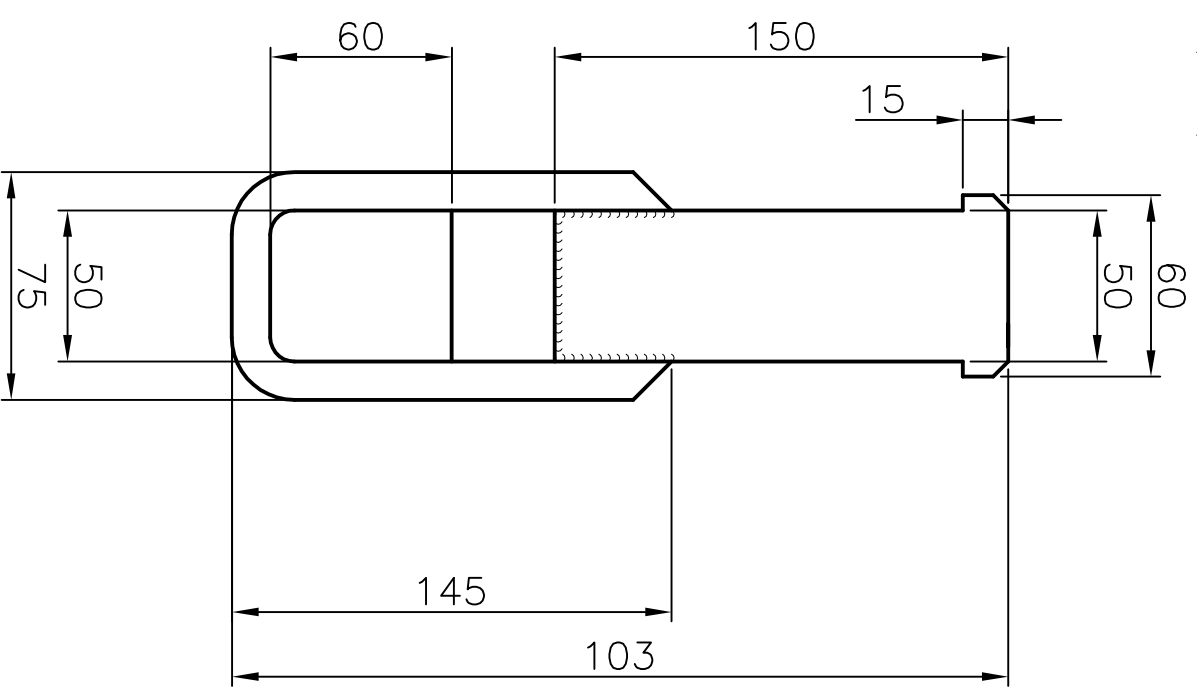
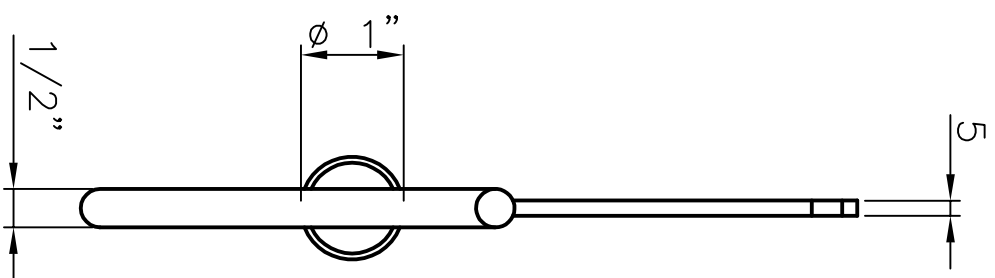

04	2m	Tie	inerttube
03	1	Guidebox frame	100 x75
02	1	Inlet rope	PVC Ø 1 1/4" - 200 mm
01	.m	Rising main	PVC Ø 1" - .m
No	Count	Name	Dimensions

Date:	07-2007
Dimension:	mm
Main scale:	1:2.5

Project:   Sungsum Veela (Walewale, Ghana)

Company:	Pumping = Life	Remarks:
Engineer:	Arnold van de Kamp	
Layout:	part	No of Layouts: 3
Name:	Guidebox 1" (Bore hole)	Revision:
		A
		A3